

PRECAUTION

- Read the following “ PRECAUTIONS ” carefully before installation.
- The air conditioner must be installed by professional technicians.
- The installation should be done in accordance with the manual.
- Please forgive delay of notice in case of any advancement.

Content

Usage

PRECAUTIONS -----	2
PARTS AND FUNCTIONS -----	4
OPERATION AND PERFORMANCE -----	6
MAINTENANCE-----	7
TROUBLE SHOOTING -----	9



Installation

PREPARATION BEFORE INSTALLATION -----	10
OUTDOOR UNIT INSTALLATION -----	11
WIRING DIAGRAM -----	22

USAGE

PRECAUTIONS

- Read the following "PRECAUTIONS" carefully before installation.
- The caution items stated here must be followed because these important contents are related to safety. The meaning of each indication used is as below.
Incorrect installation due to ignoring of the instruction will cause harm or damage, and the seriousness is classified by the following indications.

 WARNING	This indication shows the possibility of causing death or serious injury.
 CAUTION	This indication shows the possibility of causing injury or damage to properties only.

Please read the label on the principal unit carefully.

In case of such abnormal situations as abnormal noise, smelliness, smoke, temperature rising, electrical leakage, fire, please cut off the electric supply quickly and contact the dealer.



Engage dealer or specialist for installation. If installation done by user is defective, it will cause water leakage, electrical shock or fire.

Professional persons are not allowed to dismantel the unit, otherwise, accident or damage may occur.

Please do not use ort storesuch flammable gas or liquid as hair styling jelly, oil paint, petrol in case of fire.

The major electrical supply should be installed out of children touch .

Please do not spray water or other liquid in case of danger.

Please do not touch the unit with wet hands in case of electric shock.

Please cut off the electrical supply in lightning and rainy days, othwewise, danger or damage may occur.

Please cut off the major electrical supply when it is not used for a long time to avoid accidents.



Never put hands or objects into the air inlet and outlet of the indoor and outdoor unit, in case the fan with high speed may hurt you.

The baffle of the outdoor unit is not allowed to be dismantled because the fan with high speed may cause injury.



Do not let the indoor unit or remote controller be affected with damp, otherwise, Short circuit or damage may occur.

Make sure the is totally closed after the ash screen is cleaned.

Do not let it open for a long time in case of any danger.

- It suits for 18000~60000Btu/h cooling and heating capacity type. When the outdoor temperature is lower than 6°C, the system shuould be electrified over 12 hours.



● Description of symbols



Symbol	Meaning
 Warning	Mistaken operation/use may cause death or serious injury.
 Notice	Mistaken operation/use may cause injury or damage of properties only.





1. Injury means causing harmed, burned, electrical shocked, but not serious for hospitalization.
2. Damage of property means disrepair of property, material.

 Warning



	Professional installation	Do not attempt to install this unit by yourself. This unit requires installation by qualified persons, or will cause users harmed, burned electrical shocked.
	Confirm grounded wire	Confirm if it is grounded properly. If not, it may cause electrical shock.
	Measures of no less than limited density	When installing in air conditioner a small room, measures should be taken to avoid suffocation, while the leakage of refrigerant accumulates the limited density. Consult our dealers for details.

	Prohibition	Never put hands or objects into the air outlet/inlet of indoor or outdoor units. These units are installed with a fan running at high speed. To touch the moving fan will cause serious injury.
		Poweroff

Installation		Confirm Location	Do not install the AC in the place where flammable gas is prone to leaking. If flammable gas leaks and surrounds the AC, fire may be caused.
		Confirm Fixture	Ensure that the base of installation is firm. If not firm, the accident of AC's crush may occur.
		Confirm electric leakage protector	Ensure that electric system has installed creepage protector. Lack of creepage protector may cause electric shock or fire.

Usage		Check installation base	Please check the base of installation is firm and perfect when running for a long time. If not, the accident of AC's crush may occur and cause injury or death of persons.
		Disconnect manual switch	Please disconnect manual switch to stop running while sweeping. If not, high speed fan may cause damage.
		prohibition	Please choose the proper fuse. It is prohibited to use substitution or it may cause obstacle or fire.
		Prohibition	Prohibit spraying flammable spray to outdoor unit, or may cause fire.

● Description of icon

Icon	Meaning
	Contents prohibited are represented by notes or figures.
	Execution in force. Items forcibly executed are represented by notes or figures.
	Notices (including warning) items noticed and warned are represented by the notes or figures.

PARTS AND FUNCTIONS

Indoor Unit

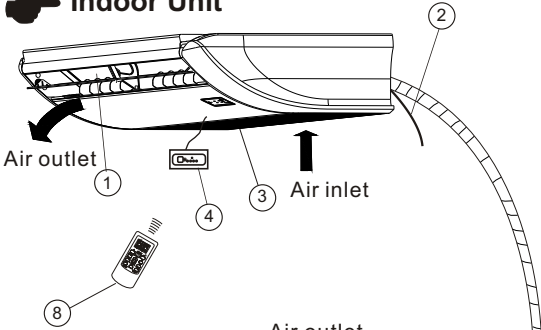

- ① Air Outlet
- ② Refrigerant Pipe Junction
- ③ Filter
- ④ Remote controller receiver
- ⑤ Refrigerant connection pipe
- ⑥ Stop valve
- ⑦ Air Outlet grille
- ⑧ Remote controller

Outdoor Unit

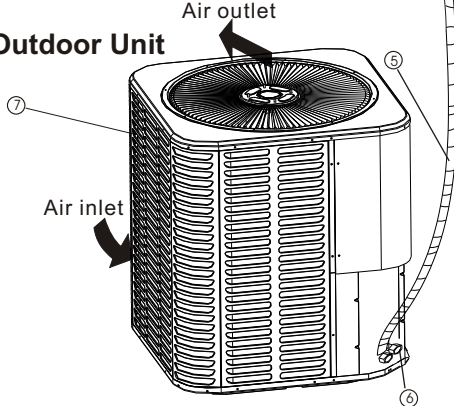

Requirements

- Do not run the unit until it has been electrified for 2 hours. Besides, if the unit stops for a day and night, please do not disconnect the power.
- Attention not to block the air outlet and inlet. It may cause the performance decreasing or start the protection device so that the unit cannot run.

DISPLAY PANEL

Infrared signal receiver: receive the signal from the remote controller.
 To make your remote controller operation more efficient, please let remote controller emitter aim at infrared signal receiver.
Buzzer: firstly powers supplied or any of remote controller operations will make the buzzer sound once.
 Some obstacles occurring in the system will be recognized by intelligent recognition system of unit, lighting on the DISPLAY PANEL flashing show the type of obstacles.

DISPLAY PANEL

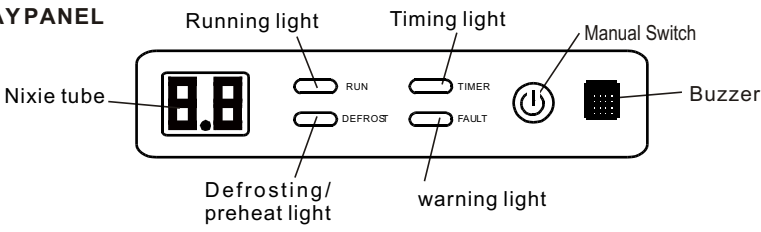

3 minutes protection

- Restart the unit at once after stopping or turning it off, compressor will not operate in the first 3min ,this phenomena is one of system functions(self-protection)。

Feature of heating

- When indoor unit operate in the heat mode, no heat air blows out till3-5min after heat exchanger being warm
- The outdoor fan motor may stop running during operation if outdoor temperature is high.

Defrost in the process of HEAT mode

- Under the condition that indoor unit operate in heat mode and heat exchanger of outdoor unit frosts.
The system will defrost for 2-10 minutes to improve heat effect,at this time drain water from outdoor unit.
- During defrosting, outdoor and indoor fan motors stop running.

Air conditioner operation conditions

The unit can be operated properly within temp range listed below.

Cooling	Outside temp	-7℃ above 43℃ below
	Room temp	17℃ above
	Room humidity	If the AC runs for a long time in COOL mode at air relative humidity higher than 80%(doors or windows opened),dew may generate and drip near air outlet.
Heating	Extertal temp	-7℃ above 21℃ below
	Room temp	31℃ below

The protective device maybe trip and stop the unit beyond temp range listed above.

Protection Device (high-pressure)

It refers to the device which stop automatically when the air conditioner is enforced to run.The indicator light still flashes when the protection device is on though running has stopped.the checking dictator lamp flashes when

protection device is on. Protection device may start under situations as follows

▲ Refrigeration is running.

- The air inlet and outlet of the outdoor unit are choked.
- Strong wind goes on blowing outlet of the outdoor unit .

▲ Heating is running

- Ash filter of the indoor .unit is overwhelmed with ashes and garbage.
- The air outlet of the indoor unit is choked.

When the protection device is running, please cut off manually operated mains switch and restart the unit after the troubles are solved.

CUT OFF ELECTRICITY

- If cut off the electricity during operation, all the running will be stopped.
- Electrify and restart the unit after the electricity is cut off, the running indicator lamp of the indoor is flashing to inform you.

■ Restart the unit till the power recovers.

When the mistaken action occur during operation,please cut off the manual switch in case the mistaken action occur during operation which is caused by thunder and wireless automobile. After turn it on again, restart the unit.

HEATING CAPACITY

- Heating is a way that heat pump absorbs heat from outside and release inside.
- Once the outside temperature decrease, the heating capacity also decrease.
- It is suggest that other heating equipments be used together when outdoor temperature is lower.
- The result will be better if the electric auxiliary heater is purchased additionally especially in the low temperature district.

OPERATION AND PERFORMANCE

CHECKS BEFORE OPERATION

- Check if the ground wire is connected well.
- Check if the air filter is installed well.
- You must clean the filter and then start the air conditioner when it is not used for a long time.
- Check that the air outlet or inlet of outdoor unit is not blocked.

BEST OPERATION

Notice the following items to ensure the system operate at best. The specific operation ways refers to the corresponding content.

Set the temperature properly to make the environment comfortable; avoid overheating or overcooling.

Use window curtain or shutter to avoid penetrated sunshine during COOL mode running.



Please close the door and window. If they are open, the cooling & heating efficiency will be worse.

Please preset the running timer by pressing TIMER key of the remote controller.

Do not put objects near the air outlet & inlet ,otherwise air conditioner efficiency will be lower and even the system will stop running.

The cooling & heating result will be influenced if the air filter is blocked. Please clean the air filter periodically.

SAFETY RULE

-  **NOTICE** The unit must be installed by professional technician and users cannot installed by themselves. Otherwise it may damage the air conditioner or it is dangerous to you.
For proper performance, please refers to the installation manual ,otherwise it may cause self-protection or dripping, the cooling & heating result reduce.
Please adjust room temperature properly, especially when the old man, children, patients stay at home. Lightening and other electromagnetic radiation may cause ill effect. If it is, please plug off the power
-  **WARNING** The power plug should not be install at the places where the children can touch, in case they play with the power plug.
In the stormy weather, please disconnect the power switch, otherwise lightening may damage it.
If the unit not be used for a long time, please cut off the power.
Before cleaning and maintaining the unit, it is safe to disconnect the power switch.
-  **DANGEROUS**
- Never put hands or objects into the air outlet of indoor or outdoor unit. Otherwise, the moving fan with high speed will cause serious injury.
 - **Do not touch the louver when it is running or it may clamp your fingers or damage the louver accessory.**
 - Never dismantle the air-in grille of the outdoor unit. To touch the moving fan at a high speed will cause serious injury.
 - **It is dangerous for children to play with the air conditioner.**
 - **Do not damper the indoor unit and remote controller. Or it may be short circuit and even fire.**
 - **Do not use the flammable gas or liquid, such as styling gel, paint, petrol etc. Otherwise fire may take place.**
 - **If abnormal situation happens, such as abnormal noise, smell, smog, temperature rising, electricity leaking. Please cut off the power immediately and contact with dealers. Do not attempt to repair the air conditioner yourself.**

MAINTENANCE

Malfuction & Handling Ways

If the following situation happens, please stop running the air conditioner and cut off the power and contact with dealers.

Malfuction Type	" Malfuction " words is shown on the wire controller and give off the sound of buzzer.
	The fuse breaks down or the breaker makes a mistake frequently.
	External material or water enter into the inside of indoor unit.
	Remote controller fail to receive or the switch operation is abnormal.
	Other unusual situation happens.

If the following situation appears, the user should check according to the following request. If the problem cannot be solved ,please contact the dealers.

Malfuction	Reason	Dealing Ways
It cannot start	Power is cut off.	Wait until the power is on.
	Power switch cannot be connected.	Get through the power switch.
	Fuse of power switch breaks down.	Replace the fuse
	The battery of remote controller is exhausted.	Replace the battery
	The time of starting the machine has not got.	Wait or cancel the TIMER setting
Air is blown out but the cooling & heating result is not good.	Temperature is not set properly.	Set the temperature properly and adjust the temperature lower or higher.
	The air filter is blocked by dust.	Clean the air filter.
	The air inlet and outlet of indoor or outdoor unit are blocked.	Clean up the blockage.
	Open the door and window	Close the door and window
Air is blown out but cannot be cooling & heating completely.	Air outlet and inlet are blocked by objects.	Eliminate the blockage first, then operate again.
	Three minutes protection of compressor	Wait
	The temperature setting is not proper.	Set the temperature properly.

⚠ Note: To avoid danger, do not replace the power wire by yourself; do not repair the air conditioner yourself.

These are not failures

Phenomenon following do not indicate any trouble

1.Usual protection

Protective function of compressor.

Compressor can not start within 3 minutes after it stops.

Cold air outlet prevention(In heating mode).

The indoor fan cannot start if indoor heat exchanger can not reach certain temperature.

(1)Heating starts just now.

(2)Defrosting is going on.

(3)Heating in low temperature (temperature is too low outside).

2. Defrosting

In heating mode, the outdoor heat exchanger may be frosted because the outside temperature is too low. The frost cover may ill effect normal heating effect for AC. Thus, AC will automatically defrost after heating mode is running for a while. In the process of defrostation, the compressor is running with the indoor and outdoor fans stop.

3. Indoor unit emit water fog

When the relative humidity is too high in cooling or dehumidity mode, the unit may emit gas like fog because of high relative humidity and great temperature drop.

When the AC return to heating after defrosting, water from defrosting may be evaporated and blown out.

4. Noise

When air conditioner is in operation or stops, sound like flowing water occurs and begins louder after 2-3 minutes.

This is the sound comes from refrigerant flowing or condensed draining water.

When AC is in operation or stops zizi sound occur due to little dilatibility of heat exchange for temperature changing.

5. ERRATIC SMELL from indoor unit

The indoor unit absorbs the odor of all the matters in the room and emits it in operation Cooling or heating

(cooling type has no such function) converts into air flowing.

When the room temperature reaches the default value, the outdoor unit will automatically stop its operation leaving air flowing only, thus, energy can be saved.

The outdoor unit will not restart until the room temperature rises (cooling mode) or lowers (heating mode) to some extent.

6. Condensation appears on the panel of the indoor unit

When it is overly humid in the room (beyond 80%), starting cooling or drying mode may bring out condensation around the air outlet of the panel.

7. Air outlet temperature of HEAT mode is not comfortable.

Air conditioner absorbs caloric from outdoor and releases to indoor in order to heat up the room air during heating process. This is the principle that the heat pump works. Heating absorption decreases when the external temperature is reduce. Its heating ability is therefore lower (refers to the right diagram). At the same time, temperature difference of indoor & outdoor strengthens and then the heating charges is heavier. If the air conditioner operation cannot attain a satisfactory result, We suggest that you can use other heating device for

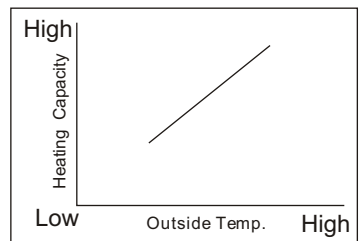

Maintenance

1. Please do the following job well if the air conditioner is not used for a long time.

In order to dry the unit completely, set the FAN mode and run for 3-4 hours.

Shut down the air conditioner and cut off the power supply.

2. When used again after the unit stops for a long period:

When cleaning the filter and indoor unit, you must stop the unit and cut off power supply. Wipe the indoor unit with soft cloth. It is forbidden to push the machine with petrol, benzene, lye, powder, detergent, insecticide etc., which will damage the unit.

Ensure air inlet and outlet of indoor and outdoor unit are not blocked by rubbish.



Check whether the grounded wire is loose and flexible, then connect the power.

After-sales service

When your air conditioner can not run in order, please shut down the machine and cut off the power supply immediately. Then contact dealers.

TROUBLE SHOOTING

Please refer to the following table before declaring repair service.

 <ul style="list-style-type: none"> ● White fog or water appear. ● Zizi sound often occur ● Bad smell ● Running lamp flashing ● Non priority or waiting lamp flashes 	<ul style="list-style-type: none"> ● Begin defrosting and stop fan motor running ● Electromagnetic valve make sounds while defrosting begins or end ● When air conditioner is in operation or stops, sound like flowing water occurs and begins louder after 2-3 minutes. This is the sound comes from refrigerant flowing or condensed draining water. ● When air conditioner is in operation or stop, su sound occur due to little dilatibility of heat exchange for temperature changing. ● Dust from wall carpet ,clothes, cigarette, cosmetic, etc attached on the air conditioner. ● Switch on the power supply after power failure, running lamp is flashing ● It does not run in the mode of cooling due to other indoor units in the mode of heating ● When the set mode is contrary to default mode (heating) ● Fan stops for preventing cool air blows out. ● When used as multi-drive unit, indicator lamp flashing and running stop.
<p>Auto stop or auto start</p>  <ul style="list-style-type: none"> ● No running 	<ul style="list-style-type: none"> ● Whether use TIMER ON button without intention ● Whether power fail; ● whether manual switch is on; ● whether the fuse breaks; ● whether the protector starts ● whether setting time of "TIMER" approach
 <ul style="list-style-type: none"> ● Cooling & heating effect is not good. 	<ul style="list-style-type: none"> ● Whether air inlet or outlet of outdoor unit is blocked ● Whether door or windows are open ● Whether the filter is accumulated by dust ● Whether the position of floater is proper; ● Whether FAN mode is set too low or whether MODE is set to END ● Whether the temperature is set properly. ● If choose the COOL and HEAT at the same time.

INSTALLATION

Important safety information

Please go through all the IMPORTANT SAFETY INFORMATION before installation.

Please install according to the installation manual.

Please read the label on the machine carefully before installation.

WARNING

Users must engage dealer or authorized specialist for installation.

Any structure modification must comply with specific construction standard.

The unit must be hung over ceilings that can bear its weight.

Power cord that is prescribed or complied with the requirement should be used.

All the electric manipulation should be done by authorized specialists according to current specification or this installation manual.

Please do not connect electric supply before installation is finished.

Please assure good ventilation when refrigerant leaks to prevent its density going beyond safety standard.

NOTICE

After the air conditioner is finished, please explain to the user about right ways of usage and maintenance. Besides, ask the user to read and keep the manual carefully.

Keep away from place with volatile oil (including engine oil) or vitriolic mist, otherwise, the inner component will be damaged with the performance greatly impaired.

Dimension of the fuse must be no less than the prescribed capacity.

Make sure an earthing breaker is installed.

Make sure a earth wire is installed.

If this air conditioner is installed on the mental part of architecture, electric installation must be done in accordance with concerning technology standard.

PREPARATION BEFORE INSTALLATION

Key points of inspection

INSTALLATION

- Be sure of machine type and name to avoid wrong installation.

Refrigerant Pipe

- Refrigerant pipe diameter must comply with the prescription.
- Refrigerant pipe must be heat-insulated.

Air purging

- Vacuum pump or refrigerant jar should be used in air purging of the connection pipe or refrigerant can be used at the gas side.

Charge additional refrigerant

- The refrigerant charge volume is based on 5m connecting pipe. If the connecting length is longer than 5m, please refer to the followings.
- please keep record of additional refrigerant charge, pipe length and height drop of indoor&outdoor unit (stick inside right panel)

Electric wiring

- Choose the electric capacity and circuit according to the design manual. The diameter of the electric supply line must be more than that of ordinary electromotor.
- Connect the electric supply after air is vacuumed.
- Wiring Specification

OUTDOOR UNIT INSTALLATION

1. Choose installation location

1.1 Inspection

As soon as a unit is received, it should be inspected for possible damage during transit. If damage is evident, the extent of the damage should be noted on the carrier's delivery receipt. A separate request for inspection by the carrier's agent should be made in writing. See local distributor for more information.

Requirements for installing/servicing R410A Equipment.

■ Gauge sets, hoses, refrigerant containers, and recovery system must be designed to handle the POE or PVE type oils.

■ Manifold sets should be 800 PSIG high side and 250 PSIG low side with 550 PSIG low side restart.

■ All hoses must have a 700 PSIG service pressure rating.

■ Leak detectors should be designed to detect refrigerant.

■ Recovery equipment (including refrigerant recovery containers) must be specifically designed to handle R410A.

■ A liquid-line filter-drier is

Required on every unit.

■ **Do not use an R-22TXV.**

See the Fig. 1

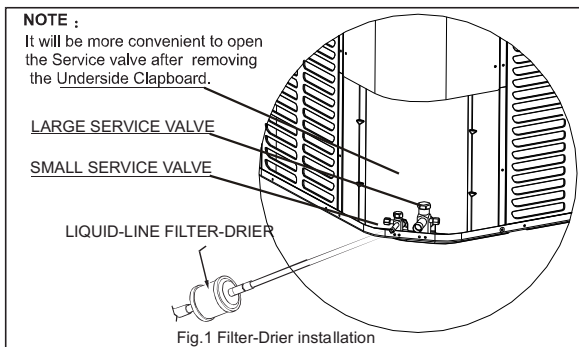

1.2 Limitations

The unit should be installed in accordance with all National, State and local safety Codes and the limitations listed below:

1. Limitations for the indoor unit, coil and appropriate accessories must also be observed.
2. The outdoor unit must not be installed with any duct work in the air stream. The outdoor fan is the propeller type and is not designed to operate against any additional external static pressure.
3. The maximum and minimum conditions for operation must be observed to assure a system that will give maximum performances and minimum services.
4. This unit is not designed to operate with a low ambient kit. Do not modify the control system to operate with any kind of low ambient kit.
5. The maximum allowable line length for this product is 150 feet (just for Scroll compressor).

2.0 General

The outdoor units are designed to be connected to a matching indoor coil with sweat connect lines. Sweat connect units are factory charged with refrigerant for a matching indoor coil plus 25 feet of field supplied lines.

Matching indoor coils are available with a thermostatic expansion valve or an orifice for most common usage. The orifice size and /or refrigerant charge may need to be changed for some indoor-outdoor unit combinations, elevation differences or total line lengths.

Air discharge: Allow 60" minimum clearance.

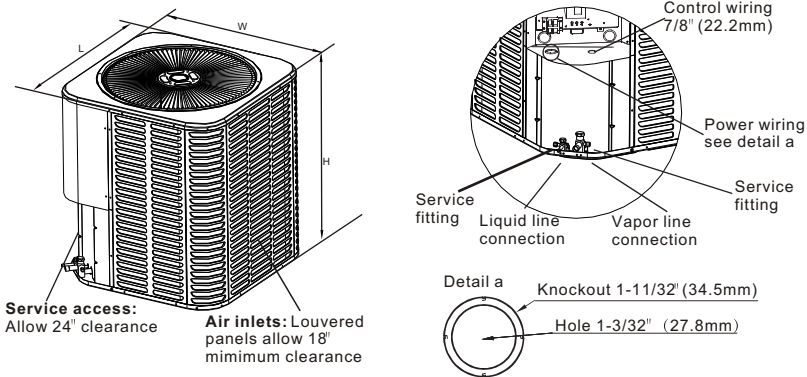

Note: grill appearance may vary.

Fig.2 Dimensions

Dimensional data

Unit Model(Btu/h)	Dimensions(Inches)			Refrigerant Connection Service Valve Size	
	W(in.)(mm)	L(in.)(mm)	H(in.)(mm)	Liquid in.	Vapor in.
18	21-7/8(554)	21-7/8(554)	24-15/16(633)	3/8	5/8
24	21-7/8(554)	21-7/8(554)	24-15/16(633)	3/8	5/8
36	23-5/8(600)	23-5/8(600)	29-7/8(759)	3/8	3/4
48	29-1/8(740)	29-1/8(740)	29-7/8(759)	3/8	3/4
60	29-1/8(740)	29-1/8(740)	33-3/16(843)	3/8	3/4

3.0 Unit installation

3.1 Location

Before starting the installation, select and check the suitability of the location for both the indoor and outdoor unit. Observe all limitations and clearance requirements. The outdoor unit must have sufficient clearance for air entrance to the condenser coil, for air discharge and for service access. See Fig.2

 **NOTE:** For multiple unit installations, units must be spaced a minimum of 18 inches apart. (Coil face to coil face.)

If the units are to be installed on a hot sun exposed roof or a black-topped ground area, the unit should be raised sufficiently above the roof or ground to avoid taking the accumulated layer of hot air in to the outdoor unit.

Provide an adequate structural support.

3.2 Ground installation

The unit may be installed on a solid base that will not shift or settle, causing strain on the refrigerant lines and possible leaks. Maintain the clearances shown in Fig.2 and install the unit in a level position.

Normal operation sound levels may be objectionable if the unit is placed directly under windows of certain rooms (bedrooms, study, etc.)

Top of unit discharge area must be unrestricted for at least 60 inches above the unit.



WARNING

The outdoor unit should not be installed in an area where mud or ice could cause personal injury.

Elevate the unit sufficiently to prevent any blockage of the air entrances by snow in areas where there will be snow accumulation. Check the local weather bureau for the expected snow accumulation. Check the local weather bureau for the expected snow accumulation in your area. Isolate the unit from rain gutters to avoid any possible wash out of the foundation.

3.3 Roof installation

When installing units on a roof, the structure must be capable of supporting the total weight of unit, including a padded frame unit, rails, etc. which should be used to minimize the transmission of sound or vibration into the conditioned space.

3.4 Unit placement

1. Provide a base in the pre-determined location.
2. Remove the shipping carton and inspect for possible damage.
3. Compressor tie-down bolts should remain tightened.
4. Position the unit on the base provided.



CAUTION

This system uses R410A refrigerant which operates at higher pressure than R-22. No other refrigerant may be used in this system. Gauge sets, hoses, refrigerant containers, and recovery system must be designed to handle R410A. If you are unsure, consult the equipment manufacturer.

The outdoor unit must be connected to the indoor coil using field supplied refrigerant grade copper tubing that is internally clean and dry .units should be installed only with the tubing sizes for approved system combinations. The charge given is applicable for total tubing lengths up to 25 feet.

 **NOTE**

Using a larger than specified line size could result in oil return problems. Using too small a line will result in loss of capacity and other problems caused by insufficient refrigerant flow. Slope horizontal vapor lines at least 1 every 20 feet toward the outdoor unit to facilitate proper oil return.

3.5 Precautions during line installation

1. Install the lines with as few bends as possible. Care must be taken not to damage the couplings or kink the tubing. Use clean hard drawn Copper tubing where no appreciable amount of bending around obstruction is necessary, if soft copper must be used, care must be taken to avoid sharp bends which may cause a restriction.
2. The lines should be installed so that they will not obstruct services access to the coil, air handling system or filter.
3. Care must also be taken to isolate the refrigerant lines to minimize noise transmission from the equipment to the structure.
4. The vapor line and liquid line must be insulated with a minimum of 1/2 foam rubber insulation (Armaflex or equivalent). Tape and suspend the refrigerant lines as shown. DO NOT allow tube metal-to-metal contact. See Fig.3
5. Use PVC piping as a conduit for all underground installation as shown in Fig.4 Buried lines should be kept as short as possible to minimize the build up of liquid refrigerant in the vapor line during long periods of shutdown.
6. Pack fiberglass insulation and a sealing material such as perma gum around refrigerant lines where they penetrate a wall to reduce vibration and retain some flexibility.

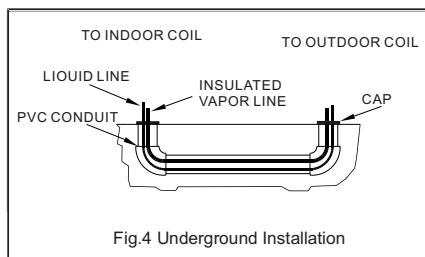
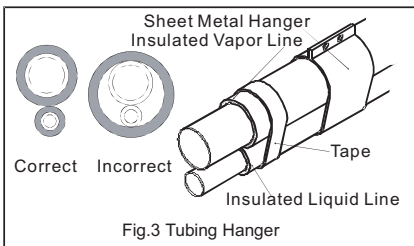

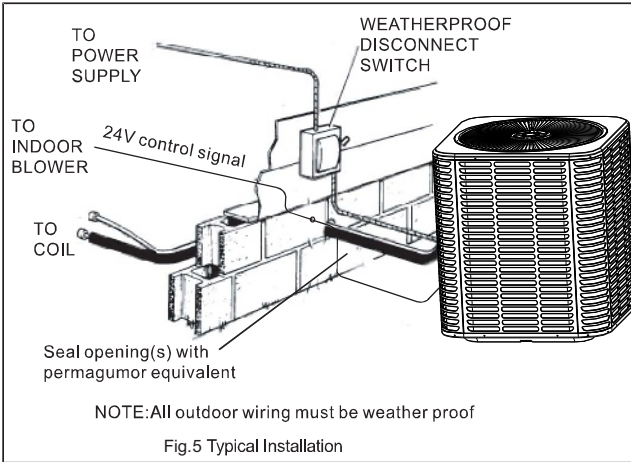

3.6 Precautions during brazing of lines

All outdoor unit evaporator coil connections are copper-to-copper and should be brazed with a phosphorous-copper alloy material such as Silfos-5 or equivalent. DO NOT use soft solder. The outdoor units have reusable service valves on both the liquid and vapor connections. The total system refrigerant charge is retained within the outdoor unit during shipping and installation. The reusable service valves are provided to evacuate and charge per this instruction.

Serious service problems can be avoided by taking adequate precautions to assure an internally clean and dry system.

CAUTION

Dry nitrogen should always be supplied through the tubing while it is being brazed, because the temperature required is high enough to cause oxidation of the copper unless an inert atmosphere is provided. The flow of dry nitrogen should continue until the joint has cooled. Always use a pressure regulator and safety valve to insure that only low pressure dry nitrogen is introduced into the tubing. Only a small flow is necessary to displace air and prevent oxidation.

3.7 Precautions during brazing service valve

Precautions should be taken to prevent heat damage to service valve by wrapping a wet rag around it as shown in Fig.6. Also, protect all painted surfaces, insulation, during brazing. After brazing cool joint with wet rag.

Valve can be opened by removing the plunger cap and fully inserting a hex wrench into the stem and backing out counter-clockwise until valve stem just touches the chamfered retaining wall.

Connect the refrigerant lines using the following procedure:

1. Remove the cap and Schrader core from both the liquid and vapor service valve service ports at the outdoor unit. Connect low pressure nitrogen to liquid line service port.

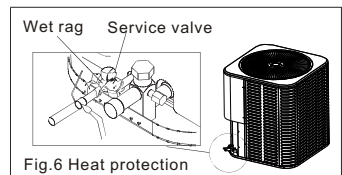

2. Braze the liquid line to the liquid valve at the outdoor unit. Be sure to wrap the valve body with a wet rag. Allow the nitrogen to continue flowing. Refer to the Tabular Data Sheet for proper liquid line sizing.
3. Carefully remove the rubber plugs from the evaporator liquid and vapor connections at the indoor coil.
4. Braze the liquid line to the evaporator liquid connection. Nitrogen should be flowing through the evaporator coil.
5. Slide the plastic cap away from the vapor connection at the indoor coil. Braze the vapor line to the evaporator connection. Refer to the table 1 for proper vapor line sizing.
6. Protect the vapor valve with a wet rag and braze the vapor line connection to the outdoor unit. The nitrogen flow should be exiting the system from the vapor service port connection. After this connection has cooled, remove the nitrogen source from the liquid fitting service port.
7. Replace the Schrader core in the liquid and vapor valves.
8. Leak test all refrigerant piping connections including the service port flare caps to be sure they are leak tight. **DONOT OVERTIGHTEN**(between 40 and 60 inch-lbs. maximum).
9. Evacuate the vapor line, evaporator and the liquid line, to 500 microns or less.

Table 1: Refrigerant Connections and Recommended Liquid and Vapor Tube Diameters (In.)

UNIT SIZE	LIQUID Tube Diameter	VAPOR Tube Diameter	LIQUID (LONG-LINE) Tube Diameter
18	3/8	5/8	5/8
24	3/8	5/8	5/8
36	3/8	3/4	3/4
48	3/8	3/4	3/4
60	3/8	3/4	3/4

10. Replace cap on service ports. Do not remove the flare caps from the service ports except when necessary for servicing the system.

 **CAUTION**

Do not connect manifold gauges unless trouble is suspected. Approximately 3/4 ounce of refrigerant will be lost each time a standard manifold gauge is connected.

11. Release the refrigerant charge into the system. Open both the liquid and vapor valves by removing the plunger cap and with an hex wrench back out counter-clockwise until valve stem just touches the chamfered retaining wall.
12. Replace plunger cap finger tight an additional 1/12 turn (1/2 hex flat). Cap must be replaced to prevent leaks.

 **WARNING**

Never attempt to repair any brazed connections while the system is under pressure. Personal injury could result.

See "System Charge" section for checking and recording system charge.

3.8 Unit mounting

If elevating the heat pump, either on a flat roof or on a slab, observe the following guidelines.

1. The base pan provided elevating a unit on a flat roof or on a slab, observe the following guidelines.
2. If elevating a unit on a flat roof, use 4"×4" (or equivalent) stringers positioned to distribute unit weight evenly and prevent noise and vibration (See fig. 7)

NOTE: Do not block drain openings shown in fig. 7

3. If unit must be elevated because of anticipated snow fall, secure unit and elevating stand such that until and/or stand will not tip over or fall off.

NOTE: Do tiedown unit, see 3.9

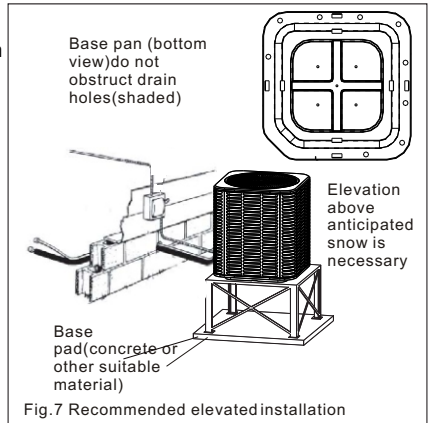

3.9 Factory-preferred tie-down method

Step 1: prior to installing clear pad of debris.

IMPORTANT

Then cement pad must be made of HVAC-approved materials and must be the proper thickness to accommodate fasteners.

step 2: Center and level unit on to pad.

Step 3: Using L-shaped bracket to locate holes on concrete and drill pilot holes which is at least 1/4" deeper than fastener being used.

IMPORTANT

self drilling screws to base pan should not exceed 3/8" long to avoid damaging coil.

step 4: Using conventional practices to install brackets, tighten concrete fasteners and self-tapping screws (See Fig. 8).

NOTE: 1. One bracket for each side. For extra stability, 2 brackets for each side.

2. Do not over-tighten the concrete fastener to avoid weakening the concrete.

IMPORTANT NOTE:

These instructions are intended to provide a method to tie-down system to cement slab as a securing procedure for high wind areas. It is recommended to check Local Codes for tie-down methods and protocols.

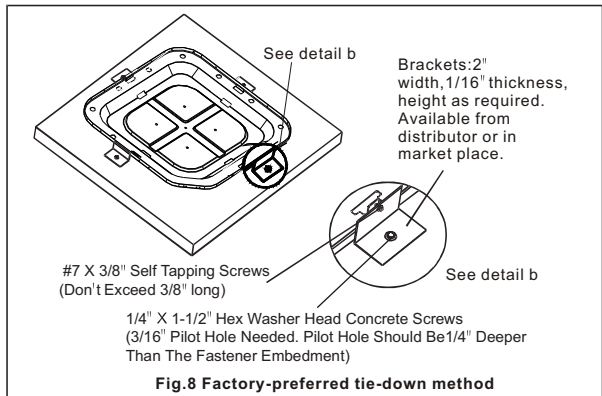

3.10 Removing the top panel and motor

When motor requires changing follow the steps below:

Step1: Go in to electrical panel, disconnect motor power lines.

IMPORTANT NOTE

Disconnect main power to unit. Severe burns and electrical shock will occur if you do not disconnect main power.

Step2: Remove cover (be careful of motor wires)

Step3: Be sure to place fan cover unit on the ground as indicated in Fig.9

IMPORTANT NOTE

Do not place or lean fan blades on the ground against surface.

Step4: Remove fan motor by removing 5/16" bolts from cover.

Step5: Remove fan blade from motor by removing 1/2" bolt and place fan on the ground

Step6: Reverse removal process to reinstall to the fan and motor.

IMPORTANT NOTE

When connecting motor wires be sure to check motor direction.

4.0 Electrical connections

4.1 General information & grounding

Check the electrical supply to be sure that it meets the values specified on the unit nameplate and wiring label.

Power wiring, control (low voltage) wiring, disconnect switches and over current protection must be supplied by the installer. Wire size should be sized per requirements.

CAUTION: All field wiring must USE COPPER CONDUCTORS ONLY and be in accordance with Local, National Fire, Safety & Electrical Codes. This unit must be grounded with a separate ground wire in accordance with the above codes.

The complete connection diagram and schematic wiring label is located on the inside surface of the unit service access panel and this instruction.

4.2 Field connections power wiring

1. Install the proper size weatherproof disconnect switch outdoors and within sight of the unit.
2. Remove the screws at the side of the corner cover. Slide corner down and remove from unit. See Fig. 10.
3. Run power wiring from the disconnect switch to the unit.
4. Route wires from disconnect through power wiring opening provided and into the unit control box.
5. Install the proper size time-delay fuses or circuit breaker, and make the power supply connections.
6. Energize the crankcase heater if equipped to save time by preheating the compressor oil while the remain installation is completed.

NOTE: When changing the motor, remove top cover first

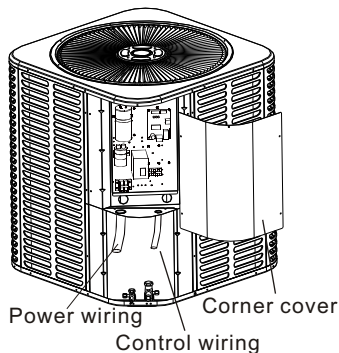
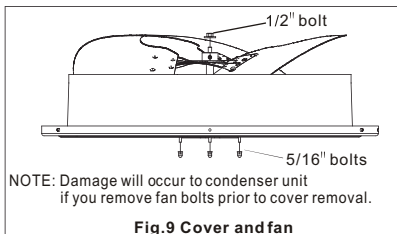

Fig. 10 Typical Field Wiring

5.0 Evacuation

It will be necessary to evacuate the system to 500 microns or less. If a leak is suspected, leak test with dry nitrogen to locate the leak. Repair the leak and test again. To verify that the system has no leaks, simply close the vacuum pump suction to isolate the pump and hold the system under vacuum. Watch the micron gauge for a few minutes. If the micron gauge indicates a steady and continuous rise, it's an indication of a leak. If the gauge shows a rise, then levels off after a few minutes and remains fairly constant, it's an indication of a leak free but still contains moisture and may require further evacuation if the reading is above 500 microns.

6.0 Interconnecting tubing

6.1 Vapor and liquid lines

Keep all lines sealed until connection is made.

Make connections at the indoor coil first.

Refer to Line Size Information in Tables 2 and 3 for correct size and multipliers to be used to determine capacity for various vapor line diameters and lengths of run. The losses due to the lines being exposed to outdoor conditions are not included.

The factory refrigerant charge in the outdoor unit is sufficient for 25 feet of interconnecting lines. The factory refrigerant charge in the outdoor unit is sufficient for the unit and 25 feet of standard size interconnecting liquid and vapor lines. For different lengths, adjust the charge as indicated below.

1/4" ± .3 oz. per foot

5/16" ± .4 oz. per foot

3/8" ± .6 oz. per foot

1/2" ± 1.2 oz. per foot

6.2 Maximum length of lines

The maximum length of interconnecting line is 150 feet.

Always use the shortest length possible with a minimum number of bends, additional compressor oil is not required for any length up to 150 feet.

NOTE: Excessively long refrigerant lines cause loss of equipment capacity.

6.3 Vertical separation

Keep the vertical separation to a minimum. Use the following guidelines when installing the unit:

1. DO NOT exceed the vertical separations as indicated on Table 3.
2. It is recommended to use the smallest liquid line size permitted to minimize system charge which will maximize compressor reliability.
3. Table 3 may be used for sizing horizontal runs.

7.0 System operation

7.1 Compressor crankcase heater (CCH)

Refrigerant migration during the off cycle can result in a noisy start up. Add a crankcase heater to minimize refrigeration migration, and to help eliminate any start up noise or "bearing" wash out".

All heaters are located on the lower half of the compressor shell. Its purpose is to drive refrigerant from the compressor shell during long off cycles, thus preventing damage to the compressor during start-up.

At initial start-up or after extended shutdown periods, make sure the heater is energized for at least 12 hours before the compressor is started. (Disconnect switch on and wall thermostat off.)

7.2 Protection function introduction

Sensor T3 (condenser pipe temperature) and T4 (outdoor ambient temperature)

When open-circuit, compressor, outdoor fan motor and reverse valve will be OFF
When $T4 < 5^{\circ}\text{F}$, compressor will stop. If the electrical heater kit is installed in the indoor Unit would provide a single to drive up the heater.
When $T4 > 10.4^{\circ}\text{F}$, compressor will restart.

Discharge temperature protection (heat pump only)

When discharge temp $> 275^{\circ}\text{F}$, compressor will stop
When discharge temp $> 194^{\circ}\text{F}$, compressor will restart

High pressure protection (heat pump only)

When high pressure $> 638\text{PSIG}$, compressor and outdoor fan motor will stop
When high pressure $> 638\text{PSIG}$, compressor and outdoor fan motor will restart
(3 minutes delay necessary)

Low pressure protection (heat pump only)

When high pressure $> 21\text{PSIG}$, compressor and outdoor fan motor will stop
When high pressure $> 44\text{PSIG}$, compressor and outdoor fan motor will restart
(3 minutes delay necessary)
In stand-by status, the compressor will not start in low pressure protection.
Within 30 mins, if 4 protection cycles occurs, system will restore after power cut-down.

8.0 Three phase compressor rotation



CAUTION

Use care when handling scroll compressor. Dome temperature can be hot.

Three phase scrolls are power phase dependent and can compress in more than one direction

Verify proper rotation for three phase compressor by ensuring the suction pressure drops and discharge pressure rises when the compressor is energized.

NOTE: when operated in reverse, a three phase scroll compressor is noisier and its current draw is substantially reduced compared to marked rated values, please check the compressor wiring; when connected to the power but the compressor does not work, the LED indicator on the PCB board of the condensing unit will flash rapidly. To correct, exchange any two of the power input terminals among the L1, L2 or L3 and this should correct problem.

When the power code connection is error, the LED indicator flashes rapidly.

When the system is in stand-by mode, the LED indicator flashes slowly

When the system is working in normal mode, LED indicator will stay lite.

9. Checking refrigerant charge

Charge for all systems should be checked against the charging chart inside the access panel cover.

IMPORTANT: Do not operate the compressor without charge in system. Addition of R-410A will raise pressures (vapor, liquid and discharge).

If adding R-410A raise both vapor pressure and temperature, the unit is over-charged.

IMPORTANT: Use industry-approved charging methods to ensure proper system charge.

9.1 Charging by liquid pressure

The liquid pressure method is used for charging systems in the cooling and heating mode. The service port on the liquid (small valve) and suction (large valve) is used for this purpose.

Verify that the outdoor unit is running and the indoor air mover is delivering the maximum airflow for this system size. Read and record the outdoor ambient temperature; Read and record the liquid and suction pressures at the ports on the liquid and suction valves. If refrigerant lines are sized using the nameplate charge, the correct liquid pressure is found at the intersection of the suction pressure and the outdoor ambient.

1. Remove refrigerant charge if the liquid pressure is above the chart value.
2. Add refrigerant charge if the liquid pressure is below the chart value.

9.2 Charging by weight

For a new installation, evacuation of interconnecting tubing and indoor coil is adequate; otherwise, evacuate the entire system. Note that charge value includes charge required for 15 ft. of standard size interconnecting liquid line. Calculate actual charge required with installed liquid line size and length using:

1/4" O.D. = .3 oz./ft.

5/16" O.D. = .4 oz./ft.

3/8" O.D. = .6 oz./ft.

1/2" O.D. = 1.2 oz./ft.

With an accurate scale (+/-1 oz.) or volumetric charging device, adjust charge difference between that shown on the unit data plate and that calculated for the new system. Installation, if the entire system has been evacuated, add the total calculated charge.

9.3 Final leak testing

After the unit has been properly evacuated and charged, a halogen leak detector should be used to detect leaks in the system. All piping within the condensing unit, evaporator, and interconnecting tubing should be checked for leaks. If a leak is detected, the refrigerant should be recovered before repairing the leak. The Clean Air Act prohibits releasing refrigerant into the atmosphere.

10.0 Instructing the owner

Assist owner with processing Warranty cards and/or online registration. Review Owners Guide and provide a copy to the owner and guidance on proper operation and maintenance. Instruct the owner or the operator how to start, stop and adjust temperature setting. The installer should instruct the owner on proper operation and maintenance of all other system components.

10.1 Maintenance

1. Dirt should not be allowed to accumulate on the outdoor coils or other parts in the air circuit. Clean as often as necessary to keep the unit clean. Use a brush, vacuum cleaner attachment, or other suitable means.
2. The outdoor fan motor is permanently lubricated and does not require periodic oiling.
3. If the coil needs to be cleaned, it should be washed with Calgon Coilclean (mix one part Coilclean to seven parts water). Allow solution to remain on coil for 30 minutes before rinsing with clean water. Solution should not be permitted to come in contact with painted surfaces.
4. Refer to the furnace or air handler instructions for filter and blower motor maintenance.
5. The indoor coil and drain pan should be inspected and cleaned regularly to assure proper drainage.

CAUTION: It is unlawful to knowingly vent, release or discharge refrigerant into the open air during repair, service, maintenance or the final disposal of this unit. When the system is functioning properly and the owner has been fully instructed, secure the owner's approval.

WIRING DIAGRAM

CAUTION: These units must be wired and installed in accordance with all national and local safety codes.

18/24/36K(Cooling Only)

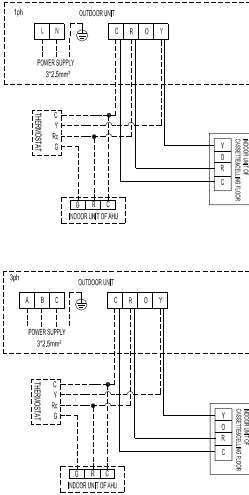

48/60K(Cooling Only)

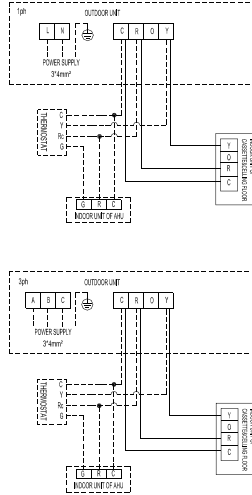

18/24/36K(Cooling and Heating)

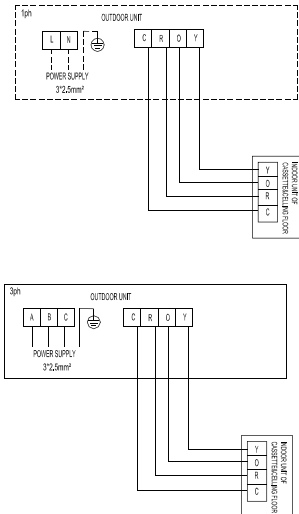

48/60K(Cooling and Heating)

